

# SGC 420

Single Genset Controller

Data sheet

4921240632C

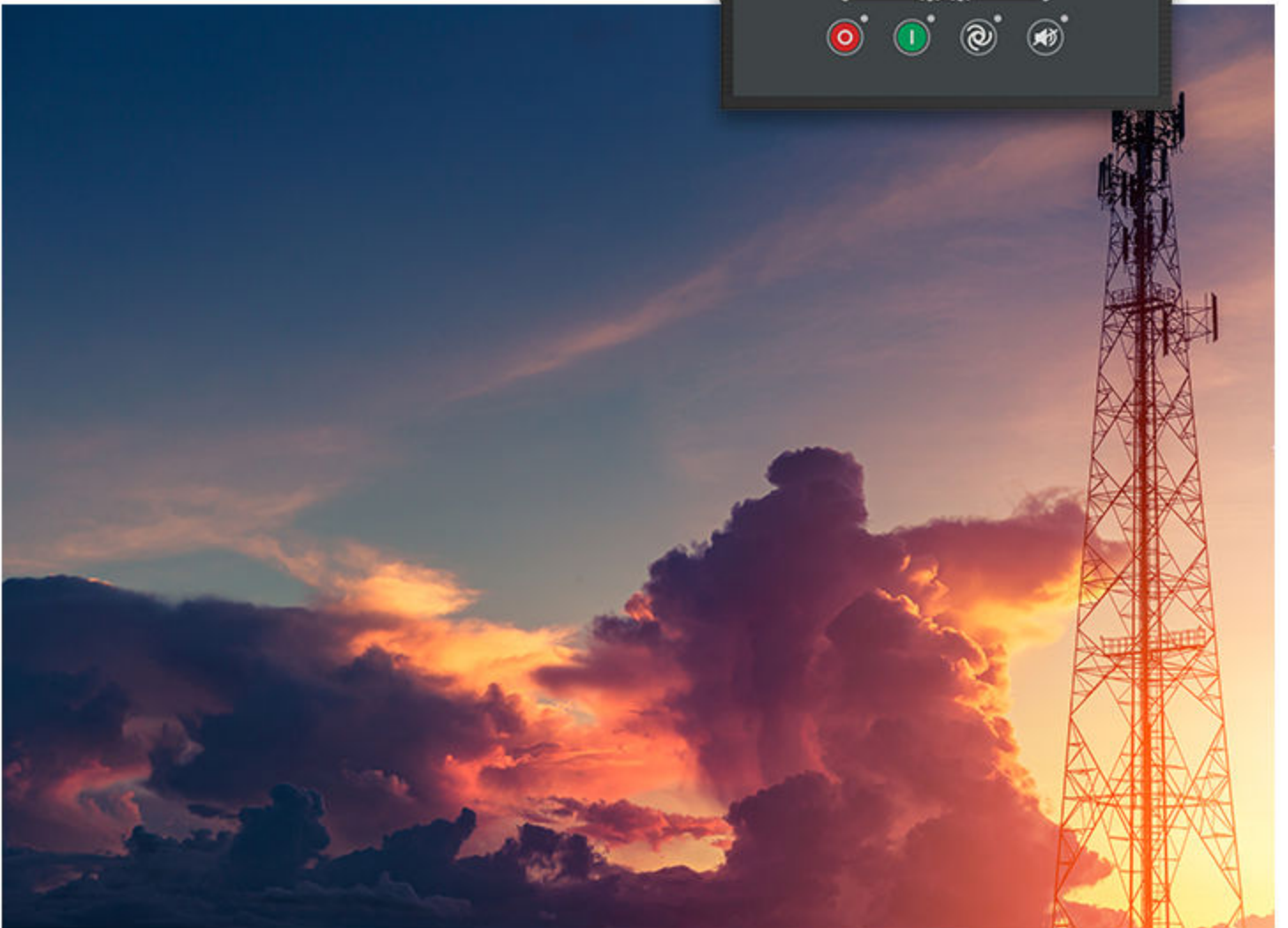

## 1. SGC 420

<b>1.1 About</b> .....	<b>3</b>
1.1.1 Software versions.....	3
<b>1.2 Single-line application diagrams</b> .....	<b>3</b>
<b>1.3 Functions</b> .....	<b>5</b>
<b>1.4 Display, buttons, and LEDs</b> .....	<b>7</b>
<b>1.5 Protections overview</b> .....	<b>7</b>

## 2. Technical specifications

<b>2.1 Electrical specifications</b> .....	<b>9</b>
2.1.1 Power supply.....	9
2.1.2 Genset voltage and frequency measurements.....	9
2.1.3 Genset current measurements.....	10
2.1.4 Earth leakage and fan current monitoring.....	10
2.1.5 Mains voltage and frequency measurement.....	10
2.1.6 Digital inputs.....	11
2.1.7 Analogue resistive sensor inputs.....	11
2.1.8 Analogue inputs used as digital inputs.....	11
2.1.9 Analogue voltage/current input.....	11
2.1.10 Site battery inputs.....	11
2.1.11 Magnetic pickup (MPU) input/W-point frequency input.....	12
2.1.12 D+ charger alternator.....	12
2.1.13 Sensor common point.....	12
2.1.14 Communication ports.....	13
2.1.15 Digital outputs.....	13
<b>2.2 Environmental specifications</b> .....	<b>13</b>
<b>2.3 Terminals</b> .....	<b>14</b>
<b>2.4 Approvals</b> .....	<b>16</b>
<b>2.5 Dimensions</b> .....	<b>17</b>

## 3. Legal information

# 1. SGC 420

## 1.1 About

The SGC 420 controller has all the functions needed to protect and control the genset, the genset breaker, and also a mains breaker. The values and alarms are shown on the LCD display screen, and operators can control the system from the display.

You can use the SGC 420 to monitor the site battery and significantly reduce your fuel consumption. You can also use the controller to monitor the shelter temperature, engine and alternator parameters, and the true RMS voltage and current.

Configure the parameters with the DEIF Smart connect software. You can also configure the parameters on the controller.

### 1.1.1 Software versions

The information in this document relates to software versions:

Software	Versions
SGC Application software	9.04

## 1.2 Single-line application diagrams

### Island mode

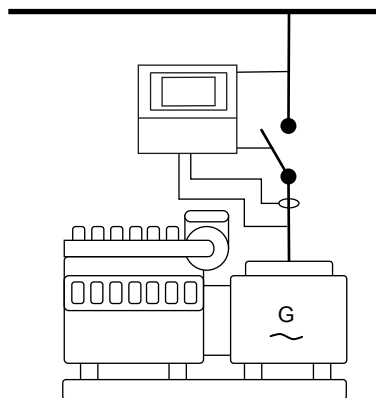

**Island:** Island mode is typically used in power plants that are isolated from other power generation systems.

### Engine drive

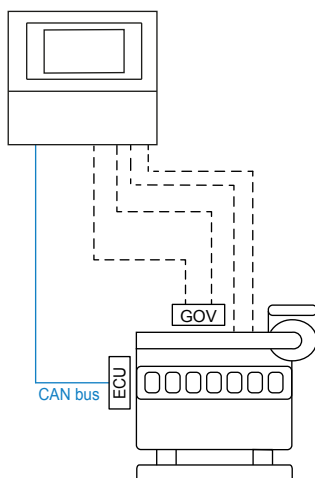

**Engine drive:** Use the controller to control one engine. The controller has all the necessary functions to control and protect the engine.

## Automatic mains failure (AMF), remote start/stop, cyclic and auto exercise mode

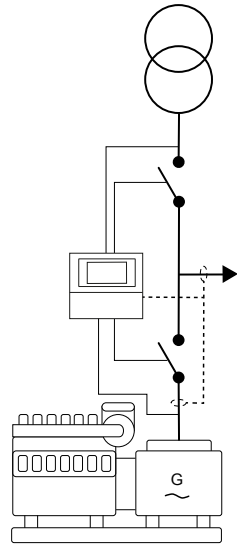

**AMF:** If there is a significant loss of mains power or a total blackout, the controller automatically changes the supply to the generator.

**Remote start/stop:** Activate the configured start/stop inputs to remotely start or stop the genset.

**Cyclic:** The genset operates for an adjustable amount of time during a mains failure.

**Exercise mode:** Use the auto exercise mode to schedule a maximum of two start/stop sequences for the genset.

**NOTE** You can place the CT on the line from the genset or on the load side.

## Site battery monitoring mode

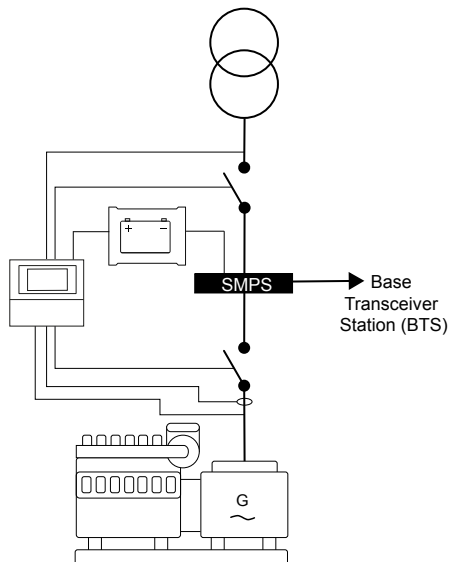

**Site battery monitoring**

**Site battery monitoring:** Use this mode to monitor the site battery and the shelter temperature.

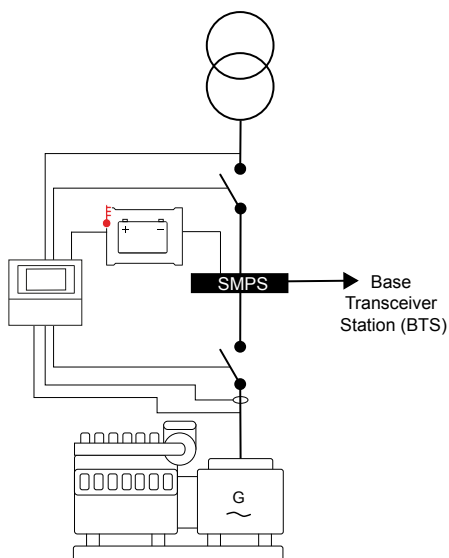

**Shelter temperature monitoring**

## 1.3 Functions

### Genset functions

Start/stop sequences

Input for genset alternator voltage or D+ charging alternator

Counters, including:

- Engine running hours
- Start attempts
- Maintenance

Input for fuel reference selection

Fuel theft alarm

Monitoring of engine and alternator parameters

Idle speed control

Coolant temperature control

Automatic fuel transfer

### Mains functions

Mains support (voltage and frequency)

Mains monitoring

### General functions

Analogue current and voltage input

Analogue resistive inputs

Digital switch input

Digital outputs

Event logs with real-time clock

EEPROM for extended event logs

Cyclic timer

Automatically clear warning alarms

2-level password protection

### Counters

Maintenance

Running hours

Genset and mains energy

### Display and language functions

Supports multiple languages, for example, English, Chinese and Spanish

Graphical display

Parameters can be changed on the display

Buttons on the display for breaker operations

Display views change automatically after an adjustable delay time

## Display and language functions

Deep sleep mode

LED lamps

## Running modes

Manual

Auto

Test

## Modes of operation

Island

Automatic mains failure (AMF)

Remote start/stop

Auto exercise

Cyclic

Site battery monitoring and shelter temperature

Night restriction mode

Engine drive

## Site battery functions

Site battery monitoring

Shelter temperature monitoring

Differential input ( $\pm 60$  V DC) for site battery voltage

## Communication

RS-485 for Modbus

USB interface to PC

CAN

## 1.4 Display, buttons, and LEDs

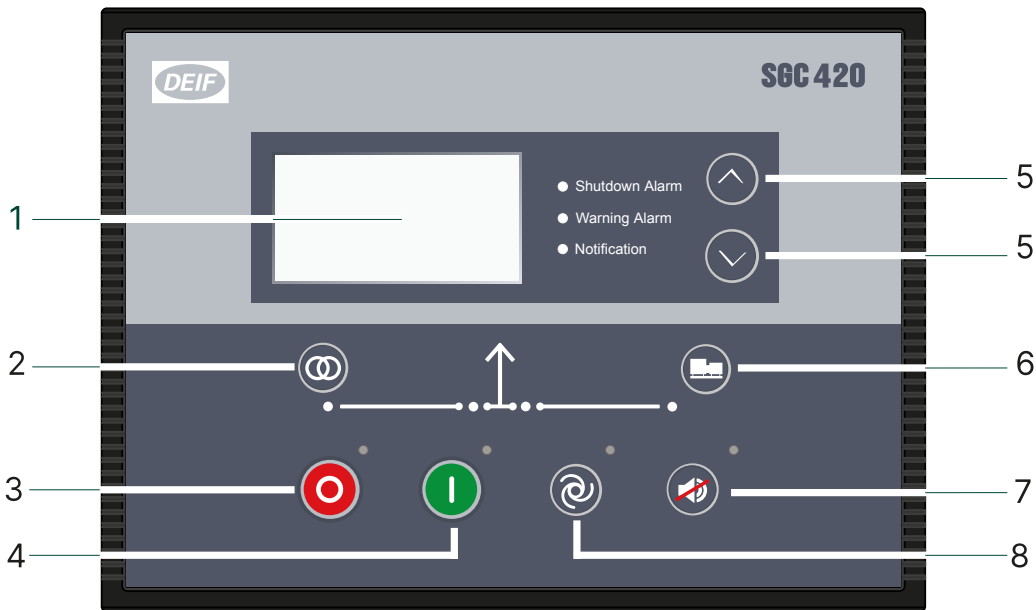

No.	Name	Function
1	Display	Graphical
2	Mains breaker symbol	Push to open or close the mains breaker.
3	Stop	Stops the genset if manual mode is selected. The controller opens the genset breaker and the cooling down time starts. If you push the Stop button twice the engine stops immediately.
3	Configure	To go to <i>Configuration menu</i> push and hold the Stop button until you see the configuration screen. To exit the configuration mode, push and hold the Stop button.  Push the Start button to select a parameter, and to save the changes you have made.
4	Start	Starts the genset if manual mode is selected.
5	Navigation	Move the selector up and down on the screen.
6	Genset breaker symbol	Push to open or close the genset breaker.
7	Acknowledge alarm	Push to acknowledge active alarms.
6	Mode selection	Push to change the running mode.

## 1.5 Protections overview

### Generator protections

Protections	No. of	ANSI
Under-voltage	x2	27P
Over-voltage	x2	59
Under-frequency	x2	81U
Over-frequency	x2	81O

Protections	No. of	ANSI
Unbalanced load	x1	-
Over-current	x1	50TD
Overload	x1	32F
Low load	x1	-
Reverse power	x1	32R
Phase reversal detection	x1	-
Earth leakage/Fan current	x1	-

### Engine protections

Protections	No. of	ANSI
Under-speed	x1	14
Over-speed	x1	12
Configurable crank connect	x1	-
Battery monitoring	x1	-
Charging alternator	x1	-
Pre-heat	x1	-
Coolant temperature	x1	-
Lube oil pressure	x1	-
Fuel level detection	x1	-
Fuel theft detection	x1	-
ECU communication failure	x1	-
ECU diagnostic lamps	x1	-

### Mains protections

Protections	No. of	ANSI
Under-voltage	x1	27P
Over-voltage	x1	59
Under-frequency	x1	81U
Over-frequency	x1	81O
Phase reversal detection	x1	-

### Other protections

Protections	No. of	ANSI
Site battery	x1	-
Shelter temperature	x1	-



## 2. Technical specifications

### 2.1 Electrical specifications

#### 2.1.1 Power supply

Category	Specification
Controller terminals	1 (Ground) 2 (Battery or DC+)
Supply voltage range	Nominal voltage: 12/24 VDC Operating range: 8 to 32 V DC
Cranking dropout period	50 ms
Maximum reverse voltage protection	-32 V DC
Measurement accuracy (battery voltage)	±1 % full scale
Resolution	0.1 V
Maximum current consumption	~ 200 mA, 12/24 V DC (not including the current load for the DC outputs)
Standby current consumption	180 mA, 12 V DC 140 mA, 24 V DC

#### 2.1.2 Genset voltage and frequency measurements

Category	Specifications
Controller terminals	54 (Neutral) 55 (L3) 56 (L2) 57 (L1)
Measurement type	True RMS
Phase-to-neutral voltage	32 to 300 V AC RMS
Phase-to-phase voltage	32 to 520 V AC RMS
Voltage accuracy	±1 % of full scale for phase-to-neutral ±1.5 % of full scale for phase-to-phase
Voltage resolution	1 V AC RMS for phase-to-neutral 2 V AC RMS for phase-to-phase
Frequency range	5 to 75 Hz
Frequency accuracy	0.25 % of full scale
Frequency resolution	0.1 Hz

**NOTE** For single phase applications, it is mandatory to connect:

- The genset phase (L1) to terminal 57 on the controller.
- The genset neutral to terminal 54 on the controller.

### 2.1.3 Genset current measurements

Category	Specifications
Controller terminals	43 and 42 (for phase L1) 45 and 44 (for phase L2) 47 and 46 (for phase L3)
Measurement type	True RMS
Maximum CT secondary current rating	5 A
Burden	0.25 VA
Measurement accuracy	±1.4 % of nominal

### 2.1.4 Earth leakage and fan current monitoring

Category	Specifications
Controller terminals	48 and 49
Measurement type	True RMS
Maximum CT secondary current rating	5 A
Burden	0.25 VA
Measurement accuracy	±1.4 % of nominal

**NOTE** Use the recommended phase sequence when you connect the current transformer (CT).

### 2.1.5 Mains voltage and frequency measurement

Category	Specifications
Controller terminals	50 (Neutral) 51 (L3) 52 (L2) 53 (L1)
Measurement type	True RMS
Phase-to-neutral voltage	32 to 300 V AC RMS
Phase-to-phase voltage	32 to 520 V AC RMS
Voltage accuracy	±2 % of full scale for phase-to-neutral ±2.5 % of full scale for phase-to-phase
Voltage resolution	1 V AC RMS for phase-to-neutral 2 V AC RMS for phase-to-phase
Frequency range	5 to 75 Hz
Frequency accuracy	0.25 % of full scale
Frequency resolution	0.1 Hz

**NOTE** For single phase applications, it is mandatory to connect:

- The mains phase (L1) to terminal 53 on the controller.
- The mains neutral to terminal 50 on the controller.

## 2.1.6 Digital inputs

Category	Specifications
Controller terminals	33, 34, 35, 36, 37, 38, 39, 40, 41
Number of inputs	9
Type	Negative switching
Maximum input voltage	+32 V
Minimum input voltage	-24 V
Current source	5 mA
Configurable parameters with software	For example, emergency stop, and remote start and stop.

## 2.1.7 Analogue resistive sensor inputs

Category	Specifications
Controller terminals	11 (Oil pressure) 12 (Fuel) 13 (Temperature) 14 (Aux 1) 15 (Aux 2)
Number of inputs	5
Type	Ratio-metric sensing
Range	10 to 5000 $\Omega$
Open circuit detection	Above 5.5 k $\Omega$
Measurement accuracy	$\pm 2$ % of full scale (up to 1000 $\Omega$ )

## 2.1.8 Analogue inputs used as digital inputs

You can use analogue inputs as digital inputs. See **Analogue inputs used as digital inputs** in the **SGC 420 User manual** for how to wire the analogue inputs and the correct settings.

## 2.1.9 Analogue voltage/current input

Category	Specifications
Controller terminal	21 (Aux 3) 23 (Aux 4)
Measurement type	Analogue voltage/current sensing
Range	0 to 5 V DC 4 to 20 mA
Accuracy	$\pm 1.25$ % of full scale

## 2.1.10 Site battery inputs

Category	Specifications
Controller terminals	24, 25
Number of inputs	2
Type	Differential

Category	Specifications
Range	$\pm 60$ V
Resolution	0.1 V
Accuracy	$\pm 2$ % of full scale

### Run hours for the site battery

The controller calculates the amount of hours the site uses the battery to operate.

The controller calculates the run hours when:

- The mains and genset breakers are open
- The site battery voltage is more than the set point for low battery voltage.

### 2.1.11 Magnetic pickup (MPU) input/W-point frequency input

Category	Specifications
Controller terminal	22
Measurement type	Single ended
Frequency range	10 Hz to 10 kHz
Input voltage range	200 mV to 45 V AC RMS

The magnetic pickup (MPU) is an inductive sensor that is installed on the engine flywheel. It is used for engine speed sensing. The output of the MPU is a sine-wave signal.

### 2.1.12 D+ charger alternator

Category	Specifications
Controller terminal	10
Voltage range	0 to $V_{BATT}$ $V_{BATT} = 8$ to 32 V DC
Excitation	PWM (power limited to 3 W, 12 V/250 mA, 24 V/125 mA)
Accuracy	$\pm 2$ % of full scale

The charge fail is a combined input and output terminal. When the genset starts, the terminal provides controlled power output to excite the charging alternator. After excitation, the controller monitors the output voltage for the charging alternator. You can configure the action for charge fail.

### 2.1.13 Sensor common point

Category	Specifications
Controller terminal	16
Range	$\pm 2$ V
Accuracy	$\pm 2$ % of full scale

Connect terminal 16 (SCP) to a solidly grounded point on the engine, for example the engine frame. Do not share the cable used for this connection with other electrical connections.

## 2.1.14 Communication ports

Category	Specifications
USB	USB 2.0 type B for connection to PC with DEIF Smart connect software
RS-485 serial port	Half duplex Max. baud rate: 115200 bps Data connection: 2-wire Common-mode operating range Maximum distance of line: 200 m Termination resistor of 120 Ω is provided between output terminals A and B
Controller terminals	30 (GND) 31 (A) 32 (B)
CAN	Baud rate: 250 kbps Packet size: 8 bytes Termination resistor of 120 Ω is provided
Controller terminals for CAN	58 and 59

Recommended cable: Belden 3105A or equivalent, 24 AWG (0.5 mm<sup>2</sup>) twisted pair, shielded, impedance 120 Ω, <40 mΩ/m, min. 95% shield coverage.

When wiring is more than 10 m, the terminal 30 must be connected to GND.

## 2.1.15 Digital outputs

Category	Specifications
Controller terminals	3, 4, 5, 6, 7, 8, 9
Number of outputs	7
Type	DC outputs
Maximum current rating	5 A (3 and 4) 1 A (5, 6, 7, 8, 9)
Configurable parameters with software	For example, start relay or fuel relay.



### More information

See **Configurable parameters** in the **User manual** for how to configure the parameters with software.

Do not connect the starter motor relay and the stop solenoid directly to output terminals on the controller. It is recommended to connect terminal 3 to start and terminal 4 to stop.

Protect the breaker relays for the genset and mains against 4 kVA surges as described in the IEC-61000-4-5 standard.

## 2.2 Environmental specifications

Operation conditions	
Operating temperature	-20 to +65 °C (-4 to +149 °F). To IEC 60068-2-1, 2
Storage temperature	-30 to +75 °C (-22 to +167 °F). To IEC 60068-2-1, 2
Vibration	2G in X,Y and Z axes for 8 to 500 Hz. To IEC 60068-2-6
Shock	15 g for 11 ms. To IEC 60068-2-27

## Operation conditions

Humidity	0 to 95 % RH. To IEC 60068-2-78
Protection degree	IP65 (front of module when installed into the control panel with the supplied sealing gasket). To IEC 60529
EMI/EMC	IEC 61000-6-2, 4

## 2.3 Terminals

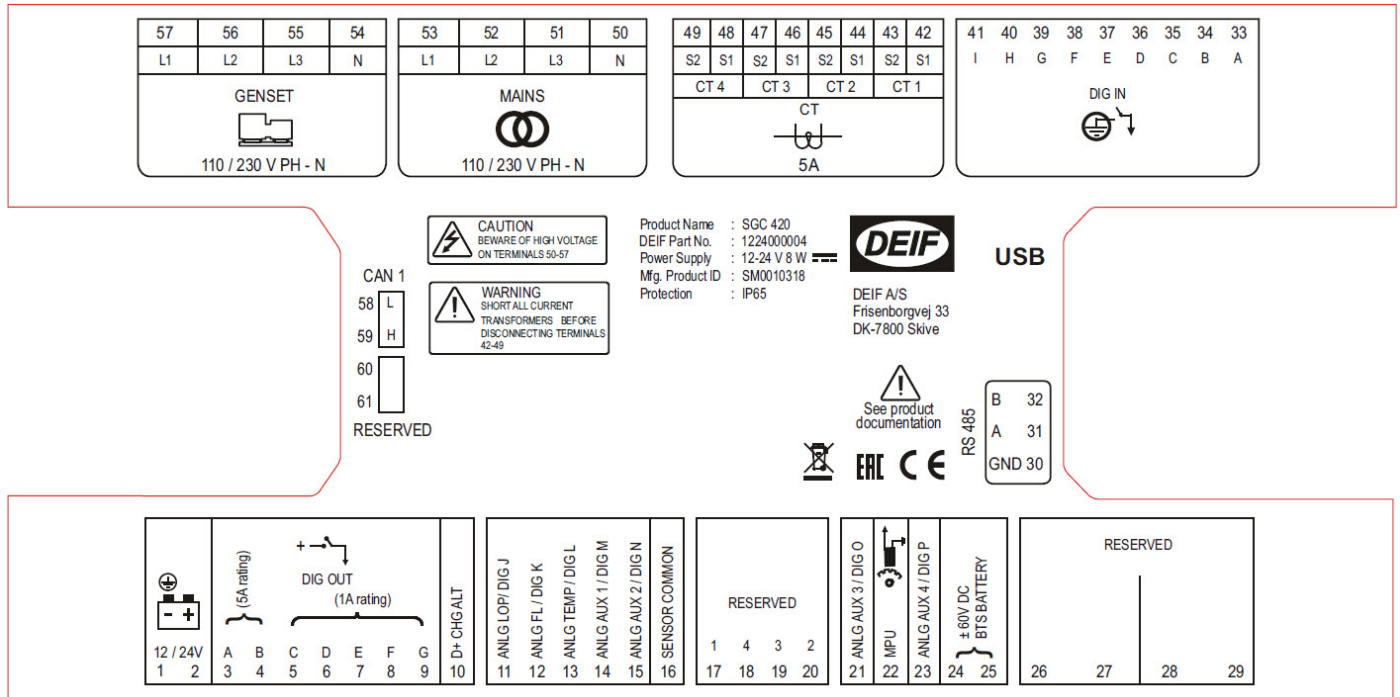

Terminal	Text	Description	Connector
1	GND	Power ground	BCP-508-10GN
2	BATT +	Power supply positive	
3	DIG OUT A	DC output - A	
4	DIG OUT B	DC output - B	
5	DIG OUT C	DC output - C	
6	DIG OUT D	DC output - D	
7	DIG OUT E	DC output - E	
8	DIG OUT F	DC output - F	
9	DIG OUT G	DC output - G	
10	D+ CHG ALT	Input for charging alternator control	

Terminal	Text	Description	Connector
11	ANLG LOP / DIG J	Analogue input from lube oil pressure sensor/ digital input J	BCP-508-6GN
12	ANLG FUEL LEVEL / DIG K	Analogue input from fuel level sensor/digital input K	
13	ANLG ENG TEMP / DIG L	Analogue input from engine temperature sensor/digital input L	
14	ANLG AUX 1 / DIG M	Analogue input auxiliary/Analogue input from shelter temperature sensor/digital input M	
15	ANLG AUX 2 / DIG N	Analogue input auxiliary/Digital input N	
16	SCP	Sensor common point	
17	RESERVED	-	N/A
18	RESERVED	-	
19	RESERVED	-	
20	RESERVED	-	
21	ANLG AUX 3/DIG O	Analogue input auxiliary/0-5 V/4-20 mA (LOP)/ digital input O	BCP-508-5GN
22	MPU	Input from engine speed sensor (inductive)	
23	ANLG AUX 4/DIG P	Analogue input auxiliary/0-5 V/4-20 mA/Digital input P	
24	BTS BATTERY ± 60 V DC	Input 1 from site battery	
25	BTS BATTERY ± 60 V DC	Input 2 from site battery	
26	RESERVED	-	N/A
27	RESERVED	-	
28	RESERVED	-	
29	RESERVED	-	
30	RS 485 GND	RS-485 GND	BCP-508-3GN
31	RS 485 A	RS-485 A	
32	RS 485 B	RS-485 B	
33	DIG IN A	Input from switch A	BCP-508-9GN
34	DIG IN B	Input from switch B	
35	DIG IN C	Input from switch C	
36	DIG IN D	Input from switch D	
37	DIG IN E	Input from switch E	
38	DIG IN F	Input from switch F	
39	DIG IN G	Input from switch G	
40	DIG IN H	Input from switch H	
41	DIG IN I	Input from switch I	

Terminal	Text	Description	Connector
42	CT 1 S1	CT input 1 from phase L1	BCP-508-8GN
43	CT 1 S2	CT input 2 from phase L1	
44	CT 2 S1	CT input 1 from phase L2	
45	CT 2 S2	CT input 2 from phase L2	
46	CT 3 S1	CT input 1 from phase L3	
47	CT 3 S2	CT input 2 from phase L3	
48	CT 4 S1	CT input 1 from earth leakage	
49	CT 4 S2	CT input 2 from earth leakage	
50	MAINS V N	Voltage input from mains neutral	BCP-508-7GN-4PA
51	MAINS V L3	Voltage input from mains phase L3	
52	MAINS V L2	Voltage input from mains phase L2	
53	MAINS V L1	Voltage input from mains phase L1	
54	GEN V N	Voltage input from gen neutral	
55	GEN V L3	Voltage input from Gen L3	
56	GEN V L2	Voltage input from Gen L2	
57	GEN V L1	Voltage input from Gen L1	BCP-508-4GN
58	CAN L (Reserved)	CAN Low	
59	CAN H (Reserved)	CAN High	
60	Reserved	-	
61	Reserved	-	

## 2.4 Approvals

Standards	
CE	Comply to the EU Low Voltage Directive: EN 61010-1 Safety requirements for electrical equipment for measurement, control, and laboratory use - Part 1: General requirements  Comply to the EU EMC: Directive EN 61000-6-2, 4
UL	UL/ULC Recognized to UL/ULC6200:2019 1st edition



## 2.5 Dimensions

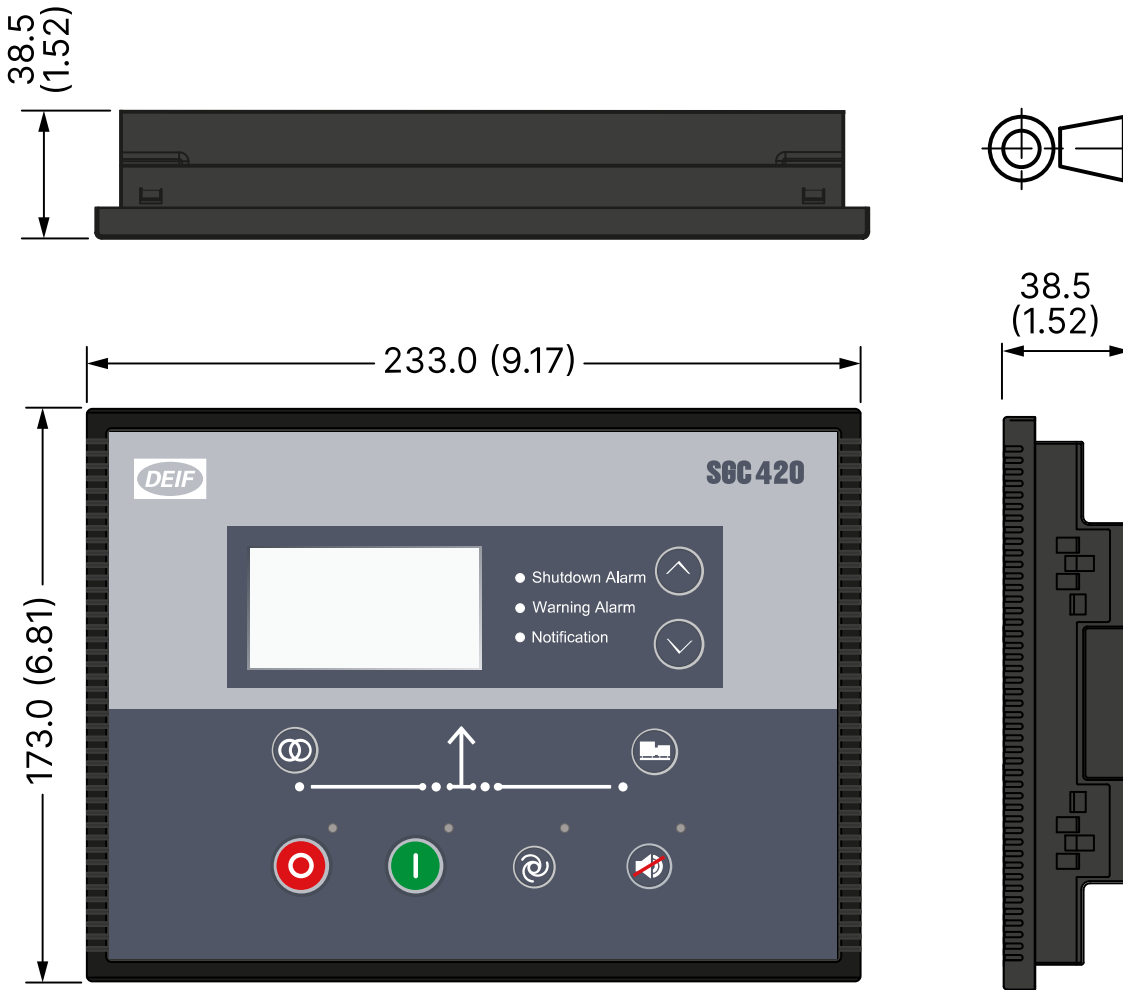

### Dimensions

Dimensions	Length: 233.0 mm (9.17 in) Height: 173.0 mm (6.81 in) Depth: 38.5 mm (1.52 in)
Panel cut-out	Length: 219.0 mm (8.62 in) Height: 158.0 mm (6.22 in) Tolerance: $\pm 0.3$ mm (0.01 in)

## 3. Legal information

### Warranty

#### NOTICE



#### **Warranty**

The controller is not to be opened by unauthorised personnel. If opened anyway, the warranty will be lost.

### Disclaimer

DEIF A/S reserves the right to change any of the contents of this document without prior notice.

The English version of this document always contains the most recent and up-to-date information about the product. DEIF does not take responsibility for the accuracy of translations, and translations might not be updated at the same time as the English document. If there is a discrepancy, the English version prevails.

### Copyright

© Copyright DEIF A/S. All rights reserved.